

Specification
for
General purpose AC Servo
High Twisting Long Life Encoder cable

Type SC-J3J2CBL M- -N

MITSUBISHI ELECTRIC
SYSTEM & SERVICE CO.,LTD

Note

Revision				Drawn	Check	Design	Approved
A	13 Nov.,2017			<i>N. Ichii</i>	<i>S. Teruya</i>	<i>F. Kazahara</i>	<i>D. Tsubokawa</i>
Send to				Date		Dwg	
				22 Mar.,2016		X903703D50052-E80A	
				Order			

1. SCOPE

This specification covers the requirements for the General purpose AC Servo High Twisting Long Life Encoder cable.

• SC-J3J2CBL□M-■-N

※ This cable doesn't include the toxic substances in RoHS (Lead, Mercury, Cadmium, Hexavalent Chromium, PBDE, PBB).

※ UL's Wiring Harnesses Traceability program provides traceability for this cable.

2. CABLE TYPE

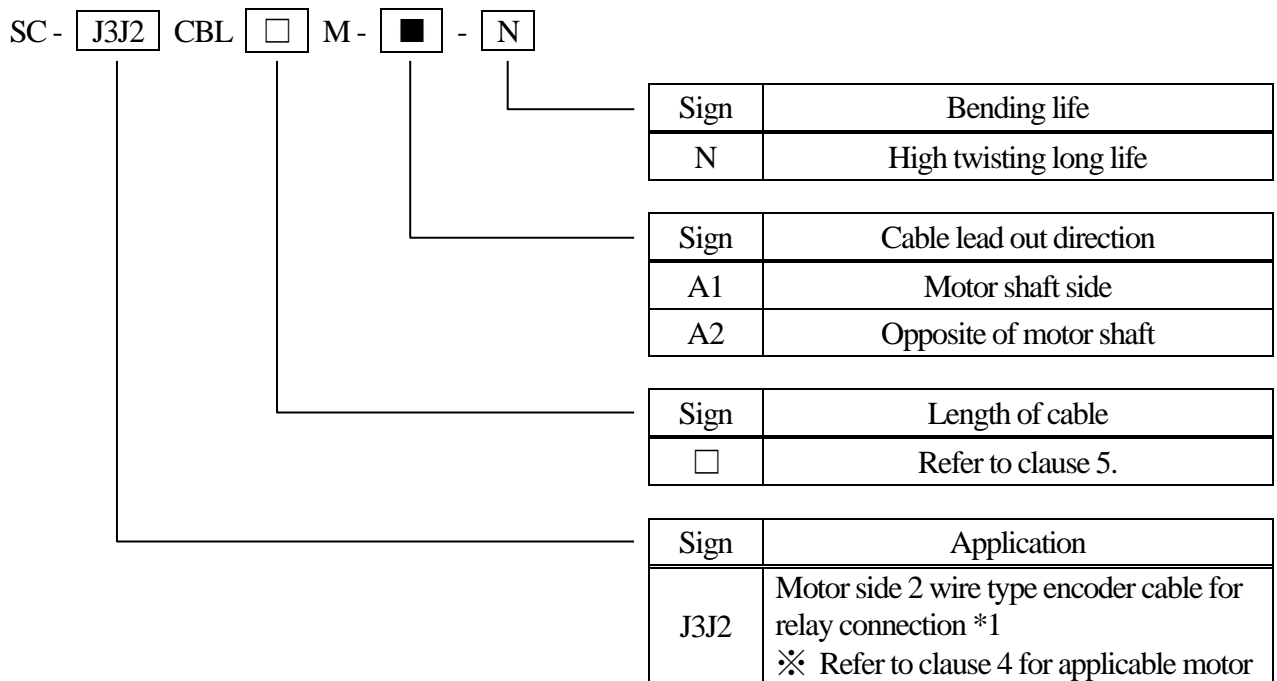

※ This cable does not work for 4 wire type connection

*1 Please use it with amplifier side encoder cable.

Refer to clause 6 for confirming the combination and cable length.

3. APPLICABLE STANDARDS

UL758 AWM STYLE 20276 (wire part)

4. APPLICABLE SERVO MOTOR

HG-KR, HG-MR series motor

HF-KN, HF-KP, HF-MP series motor

5. LENGTH OF CABLE

1 to 3m Specified by 1m unit

6. CABLE LENGTH FOR RELAY CONNECTION

Combination		Total cable length
Amplifier side	Motor side	
SC-EKCBL□M-L	SC-J3J2CBL□M-■-N	3m or less
SC-EKCBL□M-H		
SC-EKCBL□M-S	SC-J3J2CBL□M-■-N	3m or less
		20m or less

7. EXAMPLE OF PRINTING CABLE TYPE NAME

SC-J3J2CBL□M-■-N ×××××××

- ※ □ is a figure from 1 to 3.
- ※ ■ is cable lead out direction from A1,A2.
- ※ ××××××× are the serial number for seven digits.

8. STRUCTURE AND CHARACTERISTICS

Item		Unit	Specification	
Structure		—	AWG24×2C	AWG24×2P
Conductor	Conductor size	—	AWG24	
	Outer diameter	mm	Approx. 0.66	
Insulation	Material	—	ETFE	
	Outer diameter	mm	Approx. 1.02	
Twisted pair	Number of pairs	—	—	2P
	Number of insulated core wire	—	2C	2C
Shield	Material	—	Copper alloy foil braid	
Sheath	Material	—	High elastic PVC	
	Color	—	Black	
Overall diameter		mm	Approx. 7.0	
Electrical characteristics	Insulation resistance	MΩ · km	Over 500	
	Withstand voltage	V for 1 minute	AC500	
Operating temperature range		°C	-10~+60 (without condensation)	
Minimum Bend Radius		mm	6 times the overall diameter	
Twisting performance		—	Over 2 million times ^{*1} (twisting angle: ±180°)	
Flame Retardant		—	UL1581 VW-1	
Connector	Servo amplifier side	Type	Tyco electronics Japan 1-172169-9 (Plug) 316454-1 (Cable crump)	
		IP rating	IP20 ^{*2}	
	Servo motor side	Type	Tyco electronics Japan 2174053-1 (Micro motor connector)	
		IP rating	IP65 ^{*2}	

*1 This is the test result, not a guaranteed value. (The performance would change depending on customer's environment)

*2 The IP rating indicated is for the connector's protection against ingress of dust and water when coupled to a servo amplifier/servo motor. If the IP rating of the servo amplifier/servo motor differs from that of these connectors, overall IP rating depends on the lowest of all.

